

DURA-FLEX® COUPLINGS



SECTION F2



Patent No. 5,611,732

FEATURES

- Designed from the ground up using finite element analysis to maximize flex life.
- Easy two piece element installation. No need to move the hubs during replacement.
- One spacer size to handle most different between shaft spacings.
- Light weight element absorbs shock loading and torsional vibration.
- Same hubs used on both spacer and standard elements.
- No lubrication.
- Good chemical resistance.
- Stock bore-to-size (BTS), Sure-Grip bushed (QT) and Taper-Lock® bushed (TL) Hubs.

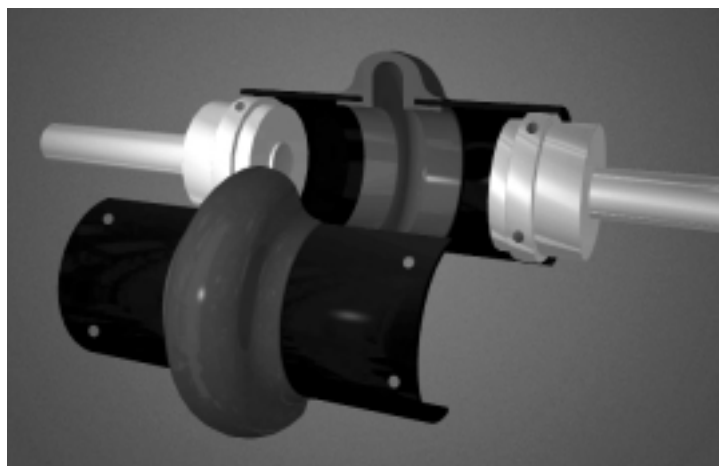

The specially designed split-in-half element can be easily replaced without moving any connected equipment.

A. Determine the Prime Mover Classification

Prime Mover	Class
• Electric Motors (Standard duty), Hydraulic Motors, Turbines	A
• Gasoline or Steam Engines (4 or more cylinders)	B
• Diesel or Gas Engines, High Torque Electric Motors	C

B. Determine the Load Characteristics and the Service Factor

Typical Applications	Load	Characteristics	Prime Mover Class		
			A	B	C
Agitators (pure liquids), Blowers (centrifugal, Can and Bottle Filling Machines, Conveyors - uniformly loaded or fed (belt, chain, screw), Fans (centrifugal), Generators (uniform load), Pumps (centrifugal), Screens (air washing, water), Stokers (uniform load), Woodworking Machines (planers, routers, saws)	Uniform	Even loads - no shock - non reversing - infrequent starts (up to 10 per hour) - low starting torques	1.0	1.5	2.0
Beaters, Blowers (lobe, vane), Compressors (centrifugal, rotary), Conveyors - non uniformly loaded or fed (belt, bucket, chain, screw), Dredge Pumps, Fans (forced draft, propeller), Kilns, Paper Mills (calendars, converting machines, conveyors, dryers, mixers, winders), Printing Presses, Pumps (gear, rotary), Shredders, Textile Machinery (dryers, dyers)	Moderate shock	Uneven loads - moderate shock Infrequent reversing-moderate torques	1.5	2.0	2.5
Cranes (bridge, hoist, trolley), Fans (cooling tower), Generators (welding), Hammer Mills, Mills (ball, pebble, rolling, tube, tumbling), Pumps (oil well), Wire Drawing Machines	Heavy shock	Uneven loads - heavy shock - frequent starts and stops - high starting torques - high inertia peak loads	2.0	2.5	3.0

Note: The above applications depict the generally accepted conditions encountered in industry. Conditions subject to extreme temperatures, abrasive dusts, corrosive liquids, excessively high starting torques, etc., must be considered as extra heavy shock loads. These conditions will increase service factors. Consult TB Wood's for these selections.

C. Calculate Design Horsepower or Design Torque

- If Prime Mover is a 1160, 1750, or 3500 rpm motor.
Design Hp = Prime Mover HP x Service Factor
Go to page F2—3 and reference the corresponding motor rpm column.
- If Prime Mover is not one of the three speeds listed above.
Design HP @ 100 rpm = (Primer Mover Hp x Service Factor x 100) / Coupling RPM
Go to page F2—3 and reference HP @ 100 RPM column.
- If Using Prime Mover Torque
Design Torque = Prime Mover Torque x Service Factor
Go to page F2—3 and reference Torque column.

D. Select Coupling (DURA-FLEX Couplings are sold by component)

A DURA-FLEX Assembly consists of one element (STD or Spacer) and two hubs (BTS or QD). Optional high speed rings may also be ordered for spacer elements. Below is an ordering example for Dura-Flex Couplings.

	Part #	Description	Size 20 Example
Element (1)	WE2 - WE80	Standard element, sizes 2 through 80	WE20
Hubs (2)	WES2 - WES80	Spacer element, sizes 2 through 80	WES20
	WE[2-80] x Bore	BTS hubs - stock bore (specify bore size)	WE20H138
HS Rings (1)	WE[4-80] - Bushing	QD hubs (sizes 4 through 80, bushing not included)	WE20H
	WE[3-80] - TL Bushing	TL hubs (sizes 3 through 80, bushing not included)	WE20HTL
	WE[20-80]R	High speed rings - sizes 20-80 (standard for sizes 2-10)	WE20R

DURA-FLEX COUPLING SELECTION (continued)



COUPLING RATINGS (STD & SPACER)

Coupling Size	HP @ RPM				Torque (IN LBS)	Stiffness in lbs/Radraw	Maximum Rpm		Max. Misalignment	
	100	1160	1750	3500			Standard	Spacer*	Parallel	Angular
WE2	.30	3.50	5.28	10.55	190	1380	7500	7500	1/16	4°
WE3	.58	6.72	10.13	20.27	365	2051	7500	7500	1/16	4°
WE4	.88	10.12	15.27	30.54	550	4141	7500	7500	1/16	4°
WE5	1.48	17.02	25.68	51.37	925	8242	7500	7500	1/16	4°
WE10	2.30	26.69	40.26	80.52	1450	12382	7500	7500	1/16	4°
WE20	3.65	42.33	63.86	127.73	2300	17193	6600	4800	3/32	3°
WE30	5.79	67.18	101.35	202.70	3650	27525	5800	4200	3/32	3°
WE40	8.85	101.23	152.72	305.43	5500	37817	5000	3600	3/32	3°
WE50	12.14	140.80	212.42	424.83	7650	48148	4200	3100	3/32	3°
WE60	19.84	230.07	347.08	694.17	12500	65342	3800	2800	1/8	2°
WE70	35.12	407.39	614.60	1229.20	22125	110625	3600	2600	1/8	2°
WE80	62.70	727.32	1097.30	2194.50	39500	197500	2000	1800	1/8	2°

*Maximum spacer RPM = Maximum standard RPM if using optional high speed rings

BTS HUBS - STOCK BORES

BORE SIZE	PRODUCT NO.*	WE2H	WE3H	WE4H	WE5H	WE10H	WE20H	WE30H	WE40H	WE50H	WE60H	WE70H	WE80H
1/2	12	O	O										
5/8	58	X	X										
3/4	34	X	X	O	O								
7/8	78	X	X	X		O	O						
1	1	X	X	X	X			O	O				
1-1/8	118	X	X	X	X	X	X						
1-1/4	114		X	X	X	X	X			O			
1-3/8	138		X	X	X	X	X						
1-1/2	112			X	X	X	X	X	X				
1-5/8	158			X	X	X	X	X	X				
1-3/4	134				X	X	X	X	X	X			
1-7/8	178				X	X	X	X	X				
2	2										O		
2-1/8	218					X	X	X	X	X		O	
2-1/4	214						X	X	X	X			
2-3/8	238						X	X	X	X		X	O
2-5/8	258											X	
2-7/8	278							X	X	X	X	X	X
3-3/8	338								X	X	X	X	X
3-3/4	334												X
3-7/8	378										X	X	X
4	4										X		
4-3/8	438											X	
4-7/8	478												X
MAX BORE		1-1/8	1-3/8	1-5/8	1-7/8	2-1/8	2-3/8	2-7/8	3-3/8	3-5/8	4	4-1/2	6

O NO KEYSEAT X STANDARD KEYSEAT MAX. BORE INCLUDES STANDARD KEYSEAT

* PRODUCT NUMBER EXAMPLE → WE5H114 for WE5 x 1-1/4 HUB

BORE TOLERANCES (BTS)

BORE SIZE	TOLERANCE
UP TO AND INCLUDING 2"	+ .0005 to + .0015
OVER 2"	+ .0005 to + .0002



DURA-FLEX BTS COUPLINGS

Assembly Dimensions for BTS Couplings.

(All dimensions in inches) Minimum Shaft Spacing = .25"

Dimensions Common to BTS Standard and Spacer Assemblies

SIZE	A	B	C	Max. Bore
WE2 & WES2	3.70	1.85	0.94	1-1/8
WE3 & WES3	4.24	2.32	1.50	1-3/8
WE4 & WES4	4.52	2.6	1.69	1-5/8
WE5 & WES5	5.40	3.13	1.75	1-7/8
WE10 & WES10	6.48	3.65	1.88	2-1/8
WE20 & WES20	7.36	4.48	2.06	2-3/8
WE30 & WES30	8.41	5.42	2.31	2-7/8
WE40 & WES40	9.71	6.63	2.50	3-3/8
WE50 & WES50	11.34	8.13	2.75	3-5/8
WE60 & WES60	12.53	8.75	3.25	4
WE70 & WES70	14.00	9.25	3.62	4-1/2
WE80 & WES80	16.00	11.3	4.87	6

Standard Element Assembly

Product No.*	OAL MAX	OAL MIN	Maximum DBSE	Weight lbs.
WE2	3.78	3.22	1.90	1.5
WE3	4.32	3.80	1.32	3.3
WE4	4.68	3.82	1.30	4.4
WE5	5.30	4.32	1.80	7.4
WE10	5.57	4.13	1.81	11.2
WE20	6.82	4.30	2.70	16.3
WE30	7.61	4.63	2.99	27.7
WE40	8.16	5.08	3.16	45.4
WE50	9.21	5.79	3.71	59.0
WE60	10.70	6.44	4.20	82.6
WE70	11.00	7.20	4.86	109.0
WE80	14.75	9.30	6.64	242.0

* Product number is element only.

Spacer Element Assembly

Product No.*	OAL MAX	OAL MIN	Maximum DBSE	Weight lbs.
WES2	5.72	5.72	4.04	2.5
WES3	8.02	7.28	5.02	4.8
WES4	8.38	7.28	5.00	6.1
WES5	8.50	7.28	5.00	9.4
WES10	8.76	7.28	5.00	13.6
WES20	11.17	9.35	7.05	19.2
WES30	11.65	9.35	7.03	31.0
WES40	11.89	9.35	6.89	48.9
WES50	12.31	9.35	6.81	63.5
WES60	16.28	12.40	9.78	91.0
WES70	16.81	12.50	9.57	128
WES80	19.73	12.50	9.77	258

* Product number is element only.

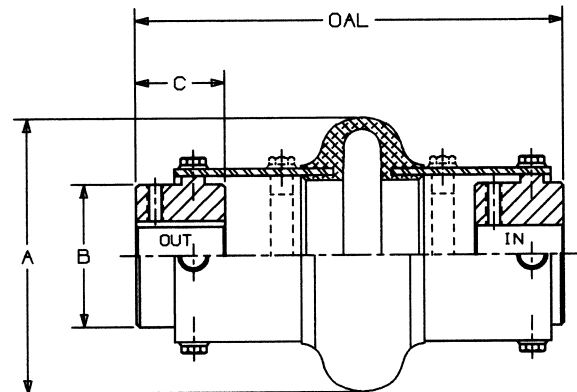
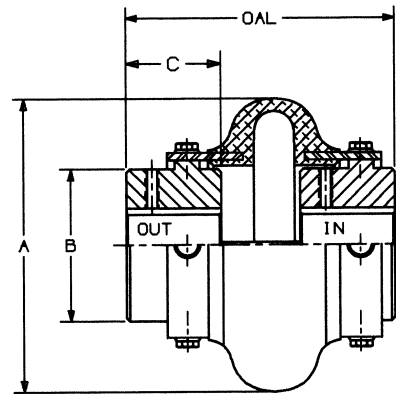

Sizes WES2 through WES10 are furnished with high speed rings. All larger sizes, rings can be ordered as an option.

All weights shown are with MPB style hubs.

Shaft Spacing from 1/4" up to the MAX DBSE can be accommodated by positioning hubs IN or OUT or by using various existing hole patterns. OAL - Over All Length does Not include bolt heads

DURA-FLEX QD BUSHED COUPLINGS



Assembly Dimensions for QD Bushed Couplings.

(All dimensions in inches) Minimum Shaft Spacing = .25"

Dimensions Common to QD Bushed Standard and Spacer Assemblies

SIZE	A	B	D	Bushing	Max. Bore
WE4 & WES4	4.52	2.60	1.00	JA	1-1/4
WE5 & WES5	5.40	3.13	1.25	SH	1-11/16
WE10 & WES10	6.48	3.65	1.31	SDS	2
WE20 & WES20	7.36	4.48	1.88	SK	2-5/8
WE30 & WES30	8.41	5.42	2.00	SF	2-15/16
WE40 & WES40	9.71	6.63	2.63	E	3-1/2
WE50 & WES50	11.34	8.13	2.63	E	3-1/2
WE60 & WES60	12.53	8.75	3.63	F	4
WE70 & WES70	14.00	9.25	4.50	J	4-1/2
WE80 & WES80	16.00	11.3	6.75	M	5-1/2

Standard Element Assembly

Product No.*	OAL MAX	OAL MIN	Maximum DBSE	Weight lbs.
WE4	3.88	3.24	1.88	3.8
WE5	4.50	4.24	1.88	6.0
WE10	4.95	3.83	2.31	8.8
WE20	6.37	4.38	2.62	15.9
WE30	5.94	5.43	2.19	25.1
WE40	6.75	6.50	1.74	47.0
WE50	7.88	6.61	2.89	48.0
WE60	8.88	8.68	1.96	79.4
WE70	10.47	10.12	1.72	124
WE80	14.72	13.97	1.47	268

* Product number is element only.

Spacer Element Assembly

Product No.*	OAL MAX	OAL MIN	Maximum DBSE	Weight lbs.
WES4	7.58	7.28	5.58	5.5
WES5	7.71	7.28	5.08	8.0
WES10	8.14	7.28	5.50	11.2
WES20	10.72	9.35	6.97	18.8
WES30	9.98	9.35	6.23	28.4
WES40	10.48	9.35	5.47	50.5
WES50	10.98	9.35	5.99	52.5
WES60	14.46	12.40	7.54	106.8
WES70	15.41	12.50	6.65	143
WES80	17.85	14.35	4.60	284

* Product number is element only.

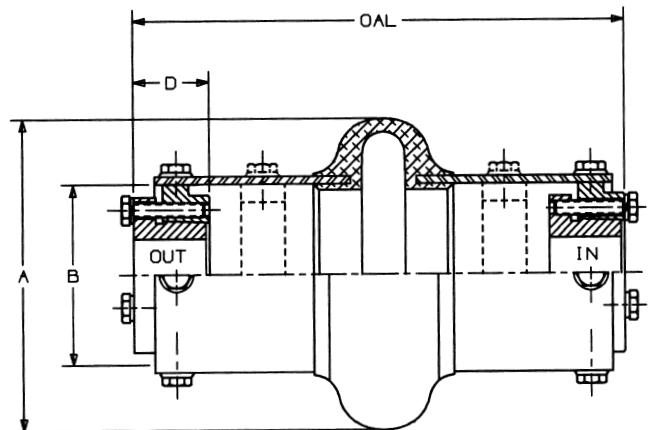
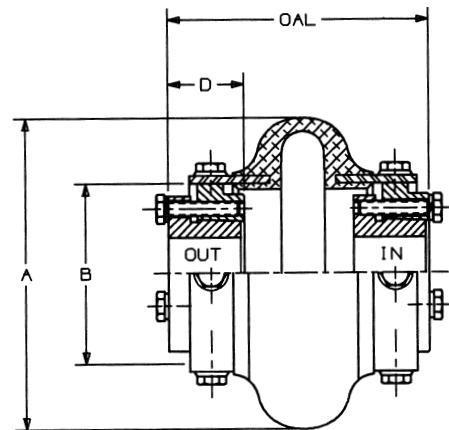

Sizes WES4 through WES10 are furnished with high speed rings. All larger sizes, rings can be ordered as an option.

All weights shown are with MPB bushings.

Shaft Spacing from 1/4" up to the MAX DBSE can be accommodated by positioning hubs IN or OUT or by using various existing hole patterns. OAL - Over All Length does Not include bolt heads

Assembly Dimensions for Taper-Lock® Bushed Couplings.

(All dimensions in inches) Minimum Shaft Spacing = .25"

Dimensions Common to Taper-Lock® Bushed Standard and Spacer Assemblies

SIZE	A	B	D	Bushing	Max. Bore
WE3 & WES3	4.24	2.32	0.88	TL1008	1
WE4 & WES4	4.52	2.60	0.88	TL1008	1
WE5 & WES5	5.40	3.13	0.88	TL1108	1-1/8
WE10 & WES10	6.48	3.65	1.00	TL1310	1-7/16
WE20 & WES20	7.36	4.48	1.00	TL1610	1-11/16
WE30 & WES30	8.41	5.42	1.25	TL2012	2-1/8
WE40 & WES40	9.71	6.63	1.75	TL2517	2-11/16
WE50 & WES50	11.34	8.13	1.75	TL2517	2-11/16
WE60 & WES60	12.53	8.75	2.00	TL3020	3-1/4
WE70 & WES70	14.00	9.25	3.50	TL3535	3-15/16
WE80 & WES80	16.00	11.3	4.00	TL4040	4-7/16

Standard Element Assembly

Product No.*	OAL	Maximum DBSE	Weight lbs.
WE3	3.44	1.69	1.8
WE4	3.44	1.69	2.6
WE5	3.94	2.19	4.0
WE10	4.06	2.06	6.0
WE20	4.50	2.50	9.0
WE30	5.06	2.56	13.6
WE40	5.88	2.38	21.8
WE50	6.50	3.00	31.5
WE60	7.31	3.31	46.6
WE70	9.38	2.38	66.7
WE80	11.75	3.75	82.0

* Product number is element only.

Spacer Element Assembly

Product No.*	OAL MAX	OAL MIN	Maximum DBSE	Weight lbs.
WES3	7.28	7.28	5.38	3.2
WES4	7.28	7.28	5.38	4.2
WES5	7.28	7.28	5.38	6.0
WES10	7.28	7.28	5.25	7.9
WES20	9.35	9.35	6.87	11.9
WES30	9.35	9.35	6.60	18.0
WES40	9.59	9.35	6.11	26.8
WES50	9.59	9.35	6.11	37.4
WES60	12.90	12.40	8.90	60.7
WES70	14.34	12.50	7.34	81.4
WES80	14.84	14.35	6.84	93.2

* Product number is element only.

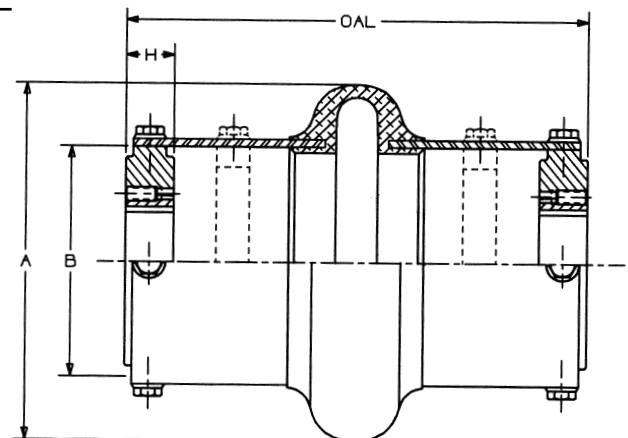
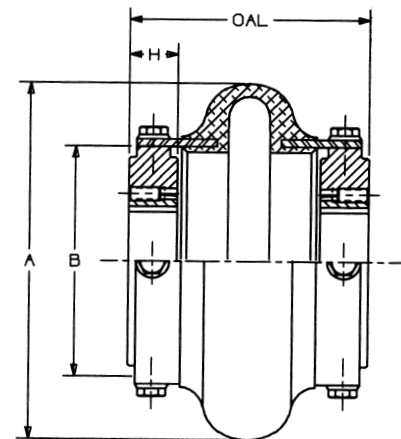

Sizes WES3 through WES10 are furnished with high speed rings. All larger sizes, rings can be ordered as an option.

All weights shown are with MPB bushings.



Patent No. 5,611,732

FEATURES

- Metric Hardware
- Designed from the ground up using finite element analysis to maximize flex life.
- Easy two piece element installation. No need to move the hubs during replacement.
- One spacer size to handle most different between shaft spacings.
- Light weight element absorbs shock loading and torsional vibration.
- Same hubs used on both spacer and standard elements.
- No lubrication.
- Good chemical resistance.

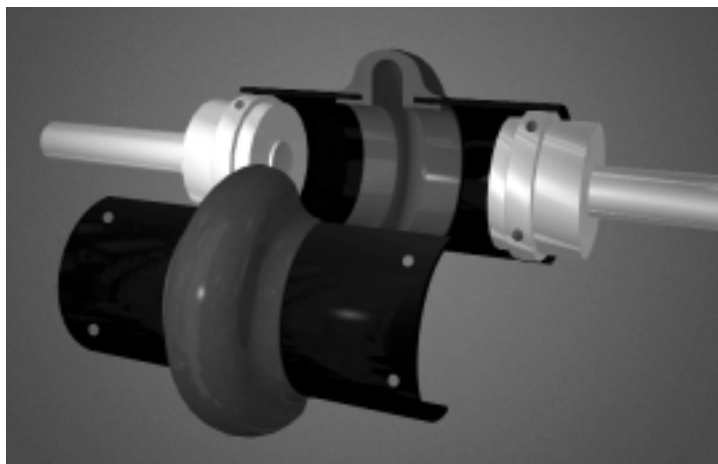

The specially designed split-in-half element can be easily replaced without moving any connected equipment.

A. Determine the Prime Mover Classification

Prime Mover	Class
• Electric Motors (Standard duty), Hydraulic Motors, Turbines	A
• Gasoline or Steam Engines (4 or more cylinders)	B
• Diesel or Gas Engines, High Torque Electric Motors	C

B. Determine the Load Characteristics and the Service Factor

Typical Applications	Load	Characteristics	Prime Mover Class		
			A	B	C
Agitators (pure liquids), Blowers (centrifugal, Can and Bottle Filling Machines, Conveyors - uniformly loaded or fed (belt, chain, screw), Fans (centrifugal), Generators (uniform load), Pumps (centrifugal), Screens (air washing, water), Stokers (uniform load), Woodworking Machines (planers, routers, saws)	Uniform	Even loads - no shock - non reversing - infrequent starts (up to 10 per hour) - low starting torques	1.0	1.5	2.0
Beaters, Blowers (lobe, vane), Compressors (centrifugal, rotary), Conveyors - non uniformly loaded or fed (belt, bucket, chain, screw), Dredge Pumps, Fans (forced draft, propeller), Kilns, Paper Mills (calendars, converting machines, conveyors, dryers, mixers, winders), Printing Presses, Pumps (gear, rotary), Shredders, Textile Machinery (dryers, dyers)	Moderate shock	Uneven loads - moderate shock - infrequent reversing-moderate torques	1.5	2.0	2.5
Cranes (bridge, hoist, trolley), Fans (cooling tower), Generators (welding), Hammer Mills, Mills (ball, pebble, rolling, tube, tumbling), Pumps (oil well), Wire Drawing Machines	Heavy shock	Uneven loads - heavy shock - frequent starts and stops - high starting torques - high inertia peak loads	2.0	2.5	3.0

Note: The above applications depict the generally accepted conditions encountered in industry. Conditions subject to extreme temperatures, abrasive dusts, corrosive liquids, excessively high starting torques, etc., must be considered as extra heavy shock loads. These conditions will increase service factors. Consult TB Wood's for these selections.

C. Calculate Design Horsepower or Design Torque

- If Prime Mover is a 970, 1450, or 3000 rpm motor.
 Design KW = Prime Mover KW x Service Factor
 Go to page F2—9 and reference the corresponding motor rpm column.
- If Prime Mover is not one of the three speeds listed above.
 Design KW @ 100 rpm = (Prime Mover KW x Service Factor x 100) / Coupling RPM
 Go to page F2—9 and reference KW @ 100 RPM column.
- If Using Prime Mover Torque
 Design Torque = Prime Mover Torque x Service Factor
 Go to page F2—9 and reference Torque column.

DURA-FLEX METRIC COUPLING SELECTION (continued)



D. DURA-FLEX Couplings are sold by component

A DURA-FLEX Assembly consists of one element (STD or Spacer) and two hubs (BTS or QD). Optional high speed rings may also be ordered for spacer elements. Below is an ordering example for Dura-Flex Couplings.

	Part #	Description	Size 20 Example
Element (1)	WE2M – WE80M	Standard Metric Element, sizes 2 through 80	WE20M
	WES2M – WES80M	Spacer Metric Element, sizes 2 through 80	WES20M
Hubs (2)	WE[2-80] MPB	BTS Hubs – MPB suitable to rebore	WE20MMPB
	WE[3-80] – TL Bushing	TL Hubs (sizes 3 through 80, bushing not included)	WE20MTL
HS Rings (1)	WE[20-80]R	High speed rings – sizes 20-80 (standard for sizes 2-10)	WE20RM

COUPLING RATINGS (STD & SPACER)

Coupling Size	KW @ RPM				Torque (Nm)	Maximum Rpm		Max. Misalignment	
	100	970	1450	3000		Standard	Spacer*	Parallel (MM)	Angular
WE2M	0.22	2.17	3.24	6.71	21.47	7500	7500	1.6	4°
WE3M	0.43	4.20	6.27	12.98	41.24	7500	7500	1.6	4°
WE4M	.66	6.37	9.52	19.69	62.14	7500	7500	1.6	4°
WE5M	1.10	10.71	16.00	33.11	104.5	7500	7500	1.6	4°
WE10M	1.72	16.64	24.87	51.45	163.8	7500	7500	1.6	4°
WE20M	2.72	26.40	39.47	81.65	259.9	6600	4800	2.4	3°
WE30M	4.32	41.88	62.61	129.53	412.4	5800	4200	2.4	3°
WE40M	6.60	64.01	95.69	197.98	621.4	5000	3600	2.4	3°
WE50M	9.05	87.81	131.27	271.58	864.3	4200	3100	2.4	3°
WE60M	14.79	143.51	214.52	443.84	1412	3800	2800	3.2	2°
WE70M	26.19	254.03	379.74	785.67	2500	3600	2600	3.2	2°
WE80M	46.76	453.53	677.95	1402.66	4463	2000	1800	3.2	2°

*Maximum spacer RPM = Maximum standard RPM if using optional high speed rings



DURA-FLEX METRIC BTS COUPLINGS

TB Wood's

Assembly Dimensions for BTS Couplings.

(All dimensions in millimeters) Minimum Shaft Spacing = 6.35mm

Dimensions Common to BTS Standard and Spacer Assemblies

SIZE	A	B	C	Max Bore
WE2M & WES2M	94	47	24	29
WE3M & WES3M	108	59	38	35
WE4M & WES4M	115	66	43	41
WE5M & WES5M	137	80	44	48
WE10M & WES10M	165	93	48	54
WE20M & WES20M	187	114	52	60
WE30M & WES30M	214	138	59	73
WE40M & WES40M	247	168	64	86
WE50M & WES50M	288	207	70	92
WE60M & WES60M	318	222	83	102
WE70M & WES70M	356	235	92	114
WE80M & WES80M	406	287	124	152

Standard Element Assembly

Product No.	OAL MAX	OAL MIN	Maximum DBSE	Weight kg
WE2M	96	82	48	.07
WE3M	110	97	34	1.5
WE4M	119	97	33	2.0
WE5M	135	110	46	3.4
WE10M	141	105	46	5.1
WE20M	173	109	69	7.4
WE30M	193	118	76	12.6
WE40M	207	129	80	20.6
WE50M	234	147	94	26.8
WE60M	272	164	107	37.5
WE70M	279	183	123	49.4
WE80M	375	236	169	110

* Product number is element only.

Spacer Element Assembly

Product No.	OAL MAX	OAL MIN	Maximum DBSE	Weight kg
WES2M	145	145	103	1.1
WES3M	204	185	128	2.2
WES4M	213	185	127	2.8
WES5M	216	185	127	4.3
WES10M	223	185	127	6.2
WES20M	284	237	27	8.7
WES30M	296	237	26	14.1
WES40M	302	237	175	22.2
WES50M	313	237	173	28.8
WES60M	414	315	248	41.3
WES70M	427	318	243	58.1
WES80M	501	318	248	117

* Product number is element only.

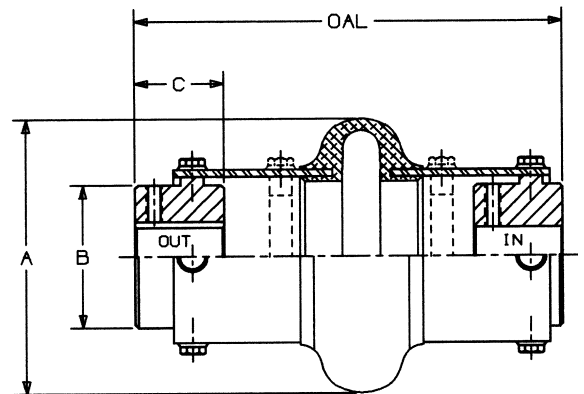
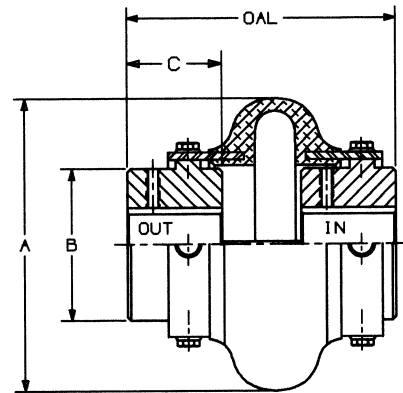

Sizes WES2M through WES10M are furnished with high speed rings. All larger sizes, rings can be ordered as an option.
All weights shown are with MPB style hubs.

Shaft Spacing from 1/4" up to the MAX DBSE can be accommodated by positioning hubs IN or OUT or by using various existing hole patterns. OAL - Over All Length does Not include bolt heads.

DURA-FLEX METRIC Taper-Lock® BUSHED COUPLINGS



Assembly Dimensions for Taper-Lock® Bushed Couplings.

(All dimensions in inches) Minimum Shaft Spacing = .25"

Dimensions Common to Taper-Lock® Bushed Standard and Spacer Assemblies

SIZE	A	B	H	Bushing	Max Bore
WE3M & WES3M	108	59	22	TL1008	26
WE4M & WES4M	115	66	22	TL1008	26
WE5M & WES5M	137	80	22	TL1108	29
WE10M & WES10M	165	93	25	TL1310	36
WE20M & WES20M	187	114	25	TL1610	44
WE30M & WES30M	214	138	32	TL2012	55
WE40M & WES40M	247	168	44	TL2517	68
WE50M & WES50M	288	207	44	TL2517	68
WE60M & WES60M	318	222	51	TL3020	82
WE70M & WES70M	356	235	89	TL3535	100
WE80M & WES80M	406	287	102	TL4040	113

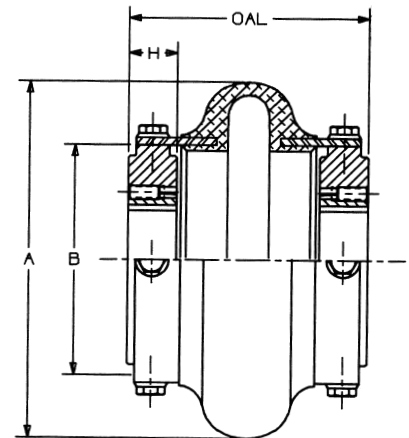

Standard Element Assembly

Product No.	OAL	Maximum DBSE	Weight kg
WE3M	87	43	0.8
WE4M	87	43	1.2
WE5M	100	56	1.8
WE10M	103	52	2.7
WE20M	114	64	4.1
WE30M	129	65	6.2
WE40M	149	60	9.9
WE50M	165	76	14.3
WE60M	186	84	21.1
WE70M	238	60	30.3
WE80M	298	95	37.2

* Product number is element only.

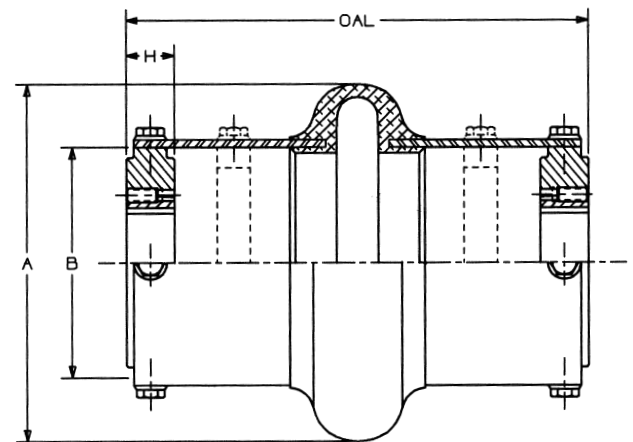

Spacer Element Assembly

Product No.	OAL MAX	OAL MIN	Maximum DBSE	Weight kg
WES3M	185	185	137	1.5
WES4M	185	185	137	1.9
WES5M	185	185	137	2.7
WES10M	185	185	133	3.6
WES20M	237	237	174	5.4
WES30M	237	237	168	8.2
WES40M	244	237	155	12.2
WES50M	244	237	155	17.0
WES60M	328	315	226	27.5
WES70M	364	318	186	36.9
WES80M	377	318	174	42.3

* Product number is element only.

Sizes WES3M through WES10M are furnished with high speed rings. All larger sizes, rings can be ordered as an option.
All weights shown are with MPB bushings.

© Taper-Lock is a registered Trademark of Rockwell Automation - Dodge

Shaft Spacing from 1/4" up to the MAX DBSE can be accommodated by positioning hubs IN or OUT or by using various existing hole patterns. OAL - Over All Length does Not include bolt heads



We Have A Product for ALL Your Coupling Needs

Besides the full line of stock DURA-FLEX couplings —
Wood's has other stock coupling lines that may fill your application.



Sure-Flex®

- Operates in shear
- No lubrication
- Four-way flexibility
- Easy installation

**Up to 115 HP
@ 100 rpm**

Gear Couplings®

- High Torque Capacity
- Torsionally Stiff
- Good Inherent Balance
- Rated for Higher Speeds
- Many Types and Configurations

**Up to 2714 HP
@ 100 rpm**



Jaw Couplings

- Economical
- No maintenance
- Industry standard
- Large inventories

**Up to 30 HP
@ 100 rpm**

Form-Flex®

- All metal construction
- No lubrication
- Wide temperature range
- Zero backlash
- API offering

**Up to 3175 HP
@ 100 rpm**

